

CAVITY TUNING

July 2017

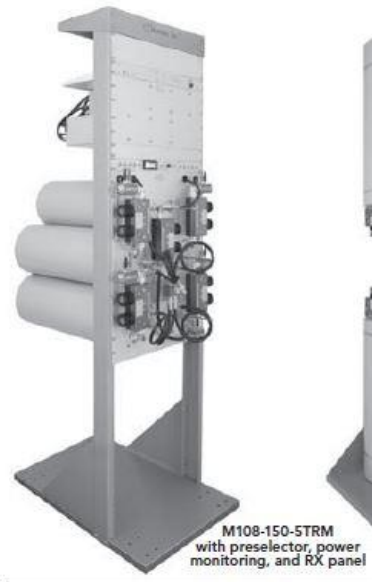

-written by Gary Moore

Telewave, Inc

- 660 Giguere Court,
San Jose, CA 95133
- Phone: 408-929-4400

Introduction

Resonant coaxial cavities are the building blocks of modern communications systems.

This paper will briefly describe the three main types of cavity filters, and how to test and tune them.

Cavities function as RF filters and provide many functions, such as:

- Prevent interaction between transmitters in combining systems,
- Reduce off channel noise (sideband, harmonic and spurious) from transmitters,
- Protect receiver front ends and AGC circuits from off channel energy.

1. Pass Cavities have two internal loops; two N-type connectors, and no in-line capacitor.
2. Pass / Reject Cavities have one internal loop, one N-type connector, and one in-line notch tuning capacitor.
3. A Notch Cavity has one internal loop; one N-type connector, and no in-line capacitor.

1. Pass cavities allow one frequency or a “window” of frequencies to pass, while attenuating or “blocking” all other frequencies.
2. Notch cavities reject one frequency or a “window” of frequencies, while allowing all other frequencies to pass. Note that a Notch Cavity has a finite pass window above and below the rejected frequency.
3. Pass / Reject Cavities have attributes of both a pass and a notch cavity in one package. Compared to the pass frequency, the notch will generally be as deep as a notch on a notch only cavity; however the blocking of all other frequencies outside the pass and notch frequencies will not be as deep as is seen with a pass cavity (example plot later in this document.) On this cavity the notch is set a certain “distance” from the pass frequency, and will tend to “follow” the pass frequency as the cavity is tuned.

Notes :

1. Telewave Wave only supports the changing of the angle of the loops, not the distance between them.
2. Adjusting the angle of the loop/s on all cavity types will change the symmetry of the Pass, Notch or combination Pass/Notch curves.
3. The coupling loops are a critical component and provide the following “Controls”:
 - Resonate Frequency = determined by the length.
 - Bandwidth = determined by the thickness and shape.
 - “Q” (sharpness of the skirt) = determined by the angle of the loop in relation to the center rod.
 - Symmetry (shape of the skirt = determined by the angle of the loop in relation to the center rod.
5. The overall wavelength of any cavity should be $\frac{1}{4}$ or $\frac{3}{4}$ WL of the fundamental frequency that is to be passed or notched. When connecting two or more cavities together, the interconnecting cables should be a multiple of $\frac{1}{4}$ or $\frac{3}{4}$ wavelength in length, so that the filter system will look like a $\frac{1}{4}$ or $\frac{3}{4}$ increment wavelength at the fundamental frequency.

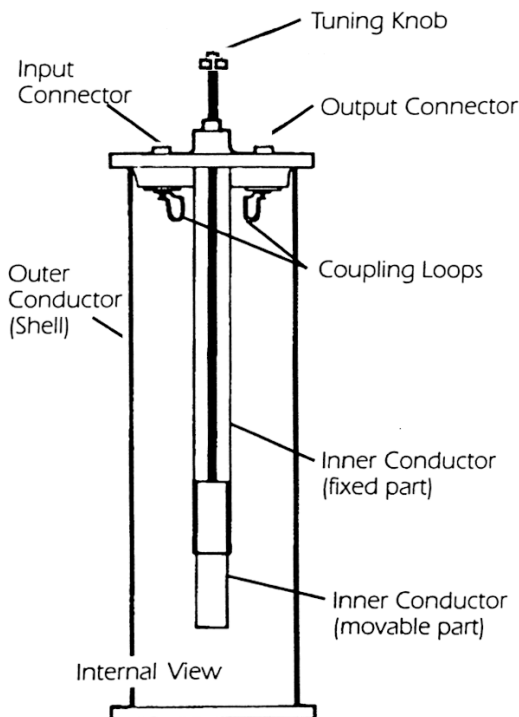
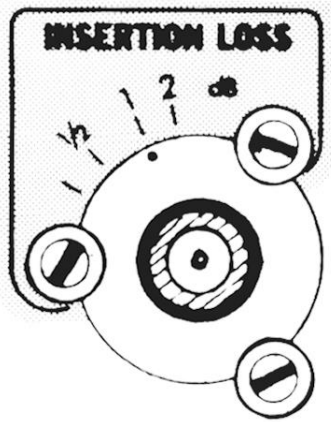

Figure 1 : Pass Cavity

INSERTION LOSS



**Figure 2 : Pass Cavity Only
(Top View)**

On a Pass Cavity Only ; it's response is adjustable by varying the position of the input and output loops. More or less coupling can be obtained by moving the loops closer or farther away from each other, and by changing the angle of the loops.

On a Pass Cavity Only ; adjusting only one loop or another will have the effect of adding a tilt or slope on the measured response. This provides more attenuation to frequencies either above or below the pass frequency of the filter when required.

CONSTRUCTION

A cavity is a metal cylinder, sometimes called a can, with welded end caps. This cylinder is resonant over a particular frequency range, which is determined primarily by the length of the cylinder. A tuning rod extends into the cylinder from the top, and allows adjustment of the cylinder to a specific frequency.

One or two N or UHF type connectors are attached to the top of the cylinder, to couple RF energy in and out of the cavity. Copper loops are attached to the connectors on the inside of the cavity. The shape and position of these loops determines the type of response which will be generated by the cavity. Cavity length is chosen to correspond to the wavelength, typically a multiple of a 1/4 wavelength, of a particular frequency band. The diameter of the cavity determines the level or amount of its response, which is discussed below. Cables of carefully controlled length and quality connect each cavity to other cavities as required in multi-cavity systems to meet the design goals of the system.

A bandpass response can also protect a receiver from de-sensitization by a nearby transmitter operating outside the desired frequency band. These cavities are used to provide isolation between transmitters in a combining system, and can be cabled in series to form a basic pre-selector.

TYPES OF CAVITIES



Band Pass

The first type of cavity is **Band Pass**. A Band pass cavities are designed to allow a certain frequency or narrow range of frequencies to pass through, while rejecting all higher or lower frequencies. The cavity also should present a 50 ohm impedance over the desired bandwidth. At frequencies outside the bandwidth, the cavity exhibit will exhibit very high impedance, and reflects all energy back towards the source. Bandpass cavities are used to suppress transmitter sideband noise, which falls outside the primary frequency range of the transmitter, and can cause destructive interference to nearby receivers or create intermodulation products in the Tx Combiner's.



Pass (low)/Reject (high)



Pass (high) Reject (low)

A second type of cavity is the **Pass-Reject**, or **Pass-Notch**. As the name implies, this is a cavity which provides a response equivalent to a combination of two of the above. A sharp notch rejects a specific frequency close to a designated operating channel, and a pass band passes the desired frequency with relatively little loss. Frequencies above or below the passband are rejected, but not as deep rejection as a pass cavity. Pass- Reject cavities are important components of duplexers designed for close TX/RX spacing.

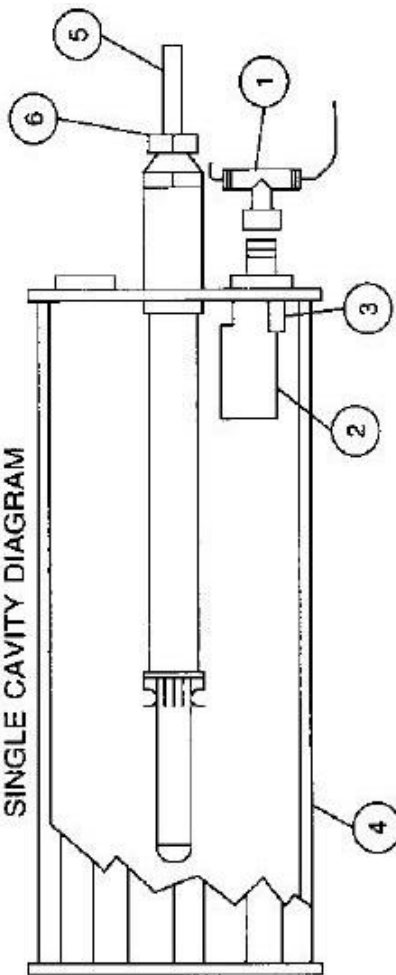

1. Main Line Tee Connector
2. Coupling Loop with 3 retaining screws
3. Variable tuning capacitor
4. Resonant cavity body
5. Sliding tuning rod
6. Tuning Rod Lock Nut



Notch

The third type of cavity is the **Band Reject** or **Notch** cavity. The notch cavity produces the opposite response of a bandpass cavity. An unwanted signal is suppressed by tuning the cavity to reflect RF energy at a specific frequency, while all other frequencies are passed through. Notch cavities protect receivers from a nearby transmitter operating on a frequency very close to the assigned channel of the receiver, while allowing the desired frequency to pass. They are also used to remove spurs or transmitter sidebands which may fall in or near the receiver passband. A single notch cavity will not provide protection from a group of transmitters operating in a given band. Notch cavities have the lowest insertion loss of the three major cavity types.

NOTE: *When transmitter power is passing through a cavity, high RF voltages and currents exist on the internal surfaces. This can cause arcing to occur during tuning, which can damage the plated cavity surfaces during tuning. Cavity tuning should be performed using a Tracking Signal Generator or Network Analyzer. If no other RF source is available, **use the lowest output power available** and make only minimal adjustments if possible.*

TEST EQUIPMENT :

See Page 12 for requirements for test equipment.

Pass Cavity Tuning

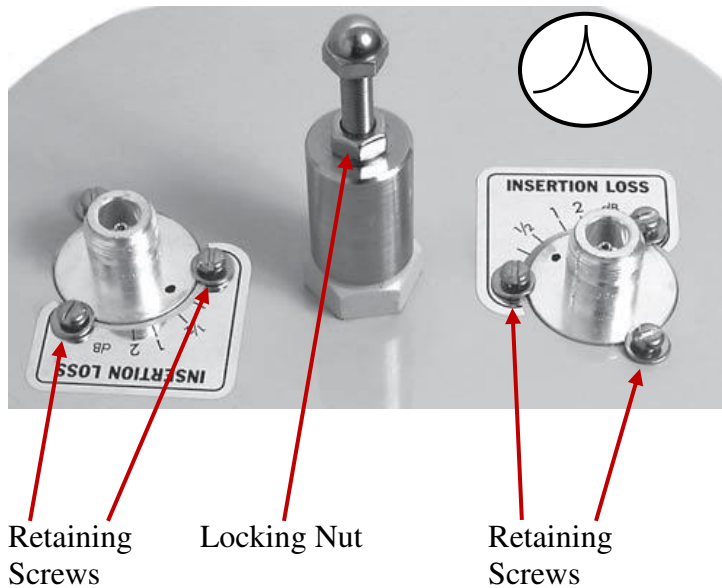

Figure 3 Pass Cavity

Theory

As the loops are rotated away from each other, the selectivity or response of the cavity increases. At the same time, a factor known as insertion or coupling loss is introduced. As loop separation increases, the amount of loss between input and output also increases. Typical loop settings range between 0.25 dB and 1 dB, but can be as high as 3 dB, while maintaining at least a 1.5 :1 VSWR.

Cavity losses and filter effects are additive, so the best approach is generally to use several cavities tuned to the desired or undesired frequency, with 0.25 dB or 0.5 dB insertion loss per cavity. Power lost due to insertion loss is dissipated as heat, so using multiple cavities also reduces the amount of power each cavity must handle.

Tuning Sequence

1. Tune each pass cavity ; one at a time
2. Then, if multiple cavities, connect all cavities and re tune as required, as some cavities may interact with each other.

Procedure

1. TUNING THE PASS FREQUENCY

A. Set the Network Analyzer to the desired pass frequency at 0 dBm output, to observe the forward transmission coefficient, or the S21. Set the frequency span, Reference Level, IF Band Width, and number of points, as desired.

B. Connect the Network Analyzer Port 1 to the input cavity connector, and Network Analyzer Port 2 to the output cavity connector.

C. Loosen the 7/16" locking nut on the center tuning shaft, and tune the shaft of the cavity for maximum response as indicated on the Network Analyzer.

2. INSERTION LOSS ADJUSTMENT

A. Set the Network Analyzer to observe the forward transmission coefficient, or the S21. Set the frequency span, Reference Level, IF Band Width, and number of points, as desired.

B. Loosen the three retaining screws around the loop connector, such that the loop assembly can be rotated. Rotate the loop until the analyzer indicates the desired insertion loss as shown on the schematic, and balanced return loss.

C. Tighten the retaining screws, and repeat Steps 1 and 2, as they both may interact with each other.

Note: If only one loop is adjusted, a slope can be introduced into the pass response, as desired.

Pass (low) / Reject (high)



Pass (high) / Reject (low)



Pass/Reject Cavity Tuning

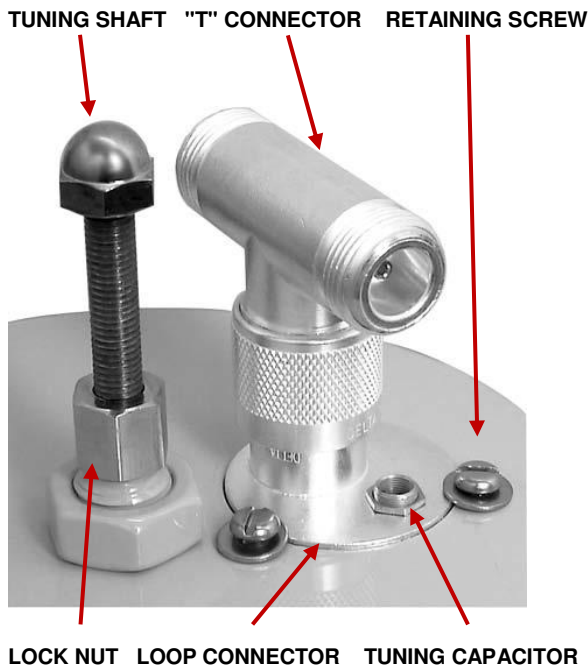

Figure 4 P/R Cavity

Theory

The response of the Pass – Reject cavity is; such that, the band pass and the notch move together as the tuning shaft is rotated. The distance of the notch from the pass frequency is adjusted by the tuning capacitor, and is independent of the setting of the pass frequency; mostly. There can be some small interaction between the two.

1. Pass Low / Reject High Cavity *will have* an 18 pf ceramic capacitor installed in parallel with the tuning capacitor.
2. A Pass High / Reject Low Cavity *will not* have the 18 pf ceramic cap bridged across the tuning capacitor.

Examine the labels on the top of the duplexer, and locate the TX and RX ports. The cavity set for TX will be PASS-TX and REJECT-RX. The cavity set for RX will be PASS-RX and REJECT-TX. If TX and RX are not marked, then you must determine which port is connected to the lower frequency device, and which is connected to the higher frequency device.

1. The cavity set for the low frequency device will be PASS-LOW and REJECT-HIGH.
2. The cavity set for the high frequency device will be PASS-HIGH and REJECT-LOW.

Tuning Sequence

For each P/R Cavity:

1. Tune pass frequency; with tuning shaft.
2. Tune reject frequency; with tuning cap.
3. Tune the insertion loss; by loosening screws, and rotate the loop connector as required.
4. Re-tune pass frequency; with tuning shaft.
5. Re-tune the reject frequency; with tuning cap.
6. Re-tune the insertion loss; by loosening screws, and rotate the loop connector as required.

If multiple P/R Cavities:

1. Connect all P/R cavities in series as required.
2. Check / re-tune pass frequency with tuning shaft; as required.
3. Check / re-tune all notch cavities for maximum notch depth; as required.
4. Check / re-tune total insertion loss by loosening the retaining screws, and rotate the loop connector as required.

Procedure

- a. First; break connection between Transmit and Receiver Cavities.
- b. Connect Performance Analyzer test cables between each individual Transmitter cavity or Receiver Cavity for their tuning, respectively.
Ref: See Figure #5 ; assuming the transmit frequencies are higher than the receive frequencies.

1. TUNING THE PASS FREQUENCY

A. Adjust the Network Analyzer to the desired **pass** frequency at 0 dBm output to observe the Forward Transmission Response ; or S21.

Set the frequency span as desired.

B. Connect the Port 1 of the Network Analyzer to one side of the cavity "T" connector, and Port 2 of the Network Analyzer to the other side of "T" connector.

C. Loosen the 7/16" locking nut on the center tuning shaft, and tune the shaft of the cavity for maximum response as indicated on the Performance Analyzer.

2. TUNING THE REJECT FREQUENCY

A. Set the Network Analyzer to the desired **reject** frequency at 0 dBm output to observe the forward transmission response ; or S21.

B. Tune the capacitor for maximum attenuation of the output signal, or minimum amplitude response, as indicated on the Performance Analyzer.

3. INSERTION LOSS ADJUSTMENT

1. Adjust the signal generator to the desired **pass** frequency at 0 dBm output.
2. Loosen the three retaining screws around the loop connector. Rotate the loop until the analyzer indicates the desired insertion loss. Tighten the retaining screws, and repeat Steps 1 and 2. An increase in the insertion loss will also increase the attenuation at the reject frequency. Minimum insertion loss occurs when the capacitor is on the opposite side of the connector, away from the center tuning rod.

***NOTE:** All tuning adjustments are mutually dependent. This means that when you adjust the capacitor, the insertion loss will change and the loop position may have to be readjusted. The center tuning may have to be touched up as well. Multiple adjustments will be required to achieve the best performance.*

On the Receiver Side:

Tune the Bandpass response to the Receive Frequency
Tune rejection on the Receiver cavities to Transmit Frequency
Note : Phasing cable (Green) on Receiver Side is trimmed to $\frac{1}{2}$ wavelength of Transmit Frequencies

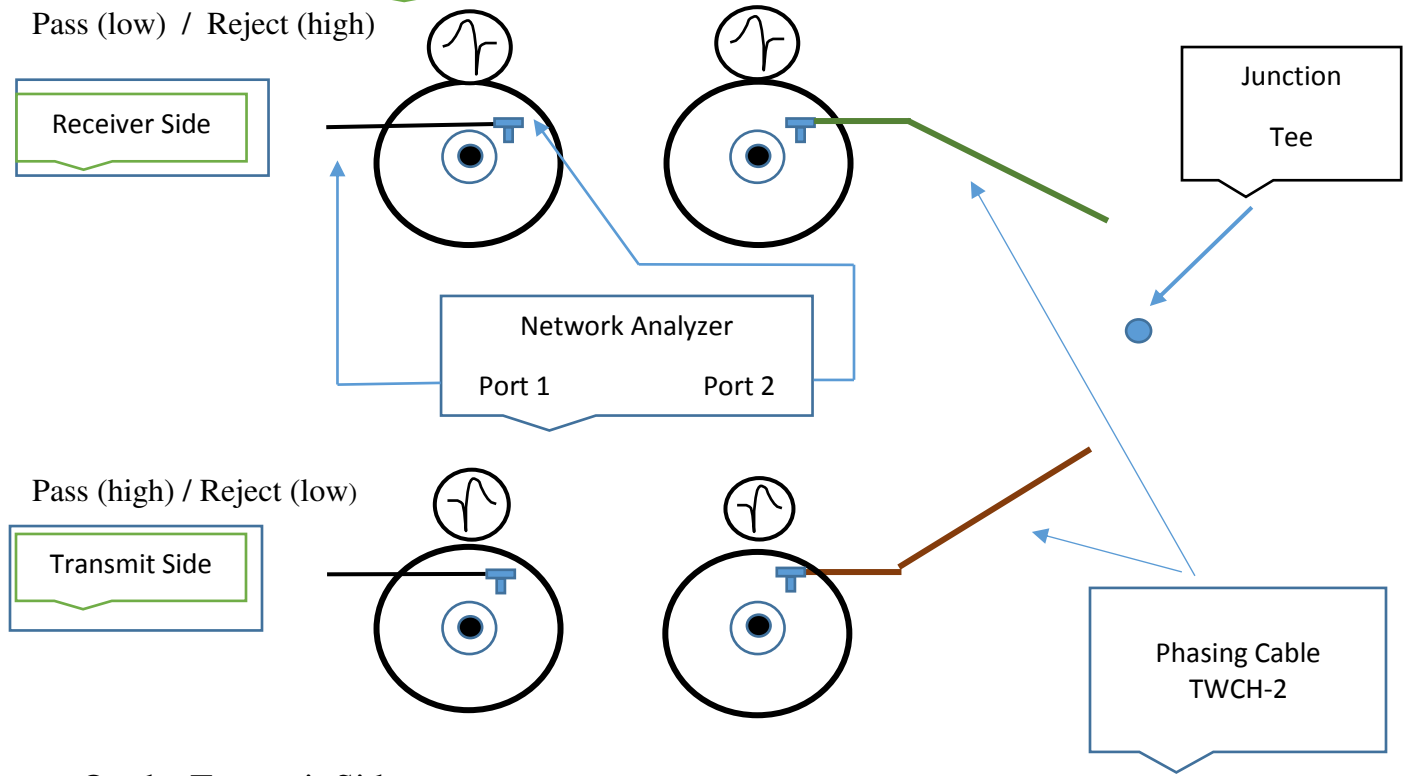

On the Transmit Side:

Tune the Bandpass response to the Transmit Frequency
Tune rejection on the Transmitter cavities to Receive frequency
Note : Phasing cable (Red) on Transmit Side is trimmed to $\frac{1}{2}$ wavelength of Receive Frequencies

Figure 5 : Pass / Reject Tuning

Procedure (continued)

- c. Re-mate connection between Transmit and Receiver Cavities to the Junction Tee.
 - d. Connect Performance Analyzer test cables between each Transmitter cavity section and Receiver Cavity section.
 - e. Re-check and re-tune; as required; all cavity tuning; Transmitter and Receiver sides respectively; as the cavity responses may interact with each other.
- Ref: See Figure #6; assuming the transmit frequencies are higher than the receive frequencies.

On the Receiver Side:

Check / Re-tune the Bandpass response to the Receive Frequency
 Check / Re-tune rejection on the Receiver cavities to Transmit Frequency

Note: Phasing cable (Green) on Receiver Side is trimmed to 1/2 wavelength of Transmit Frequencies

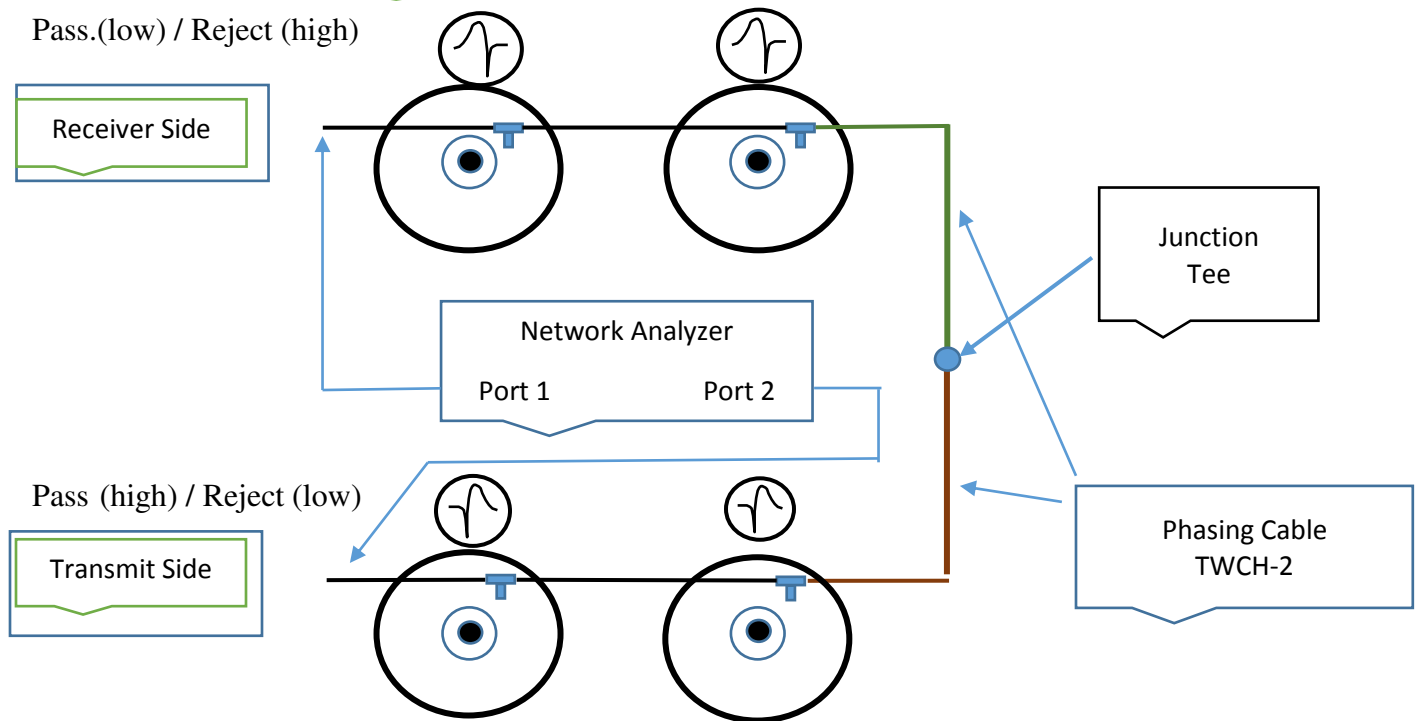

Tune the Bandpass response to the Transmit Frequency
 Tune rejection on the Transmitter cavities to Receive frequency

Note: Phasing cable (Red) on Transmit Side is trimmed to 1/2 wavelength of Receive Frequencies

Figure 6: Pass / Reject Tuning

Band Reject or Notch Cavity Tuning.



Junction Tee

Tuning Plunger

Figure 7 Notch Cavity

Theory

Well, as we look at the top of the Notch Cavity; is a single connector with attached N-Type Tee connector, and tunable plunger adjustment. As implied, a Notch Cavity Filter is a shunt filter tuned to a singular band-stop frequency.

The return loss of this cavity is measureable. The return loss of the cavity at the reject frequency will

simply track the tuned reject frequency. However, important to understand, away from the tuned reject frequency, the return loss or “impedance” of the cavity goes back up to near zero, and passes all frequencies above and below the tuned reject frequency. In this way, the pass frequencies are not “shunted” to ground.

Note: The plug on the other side of the cavity covers an existing hole in the production “can”, and is not used for this product.

Tuning Sequence

1. Tune each reject cavity ; one at a time
2. Then, if multiple cavities, connect all cavities as shown on the site drawing, and re tune as required, as some cavities may interact with each.

Procedure

1. TUNING THE REJECT FREQUENCY

A. Set the Network Analyzer to the desired reject frequency at 0 dBm output, to observe the forward transmission coefficient, or the S21.

Set the frequency span, Reference Level, IF Band Width, and number of points, as desired.

B. Connect the Network Analyzer Port 1 to one side Junction Tee connector, and Network Analyzer Port 2 to the other side of the Junction Tee connector.

C. Loosen the 7/16" locking nut on the center tuning shaft, and tune the shaft of the cavity for minimum response as indicated on the Network Analyzer.

Note: In order to measure the rejection on a Network Analyzer; it is suggested to adjust the frequency span to as narrow bandwidth as practical; and set the IF bandwidth to it's more narrow setting.

For example, on the HP 8714 analyzer, it's most narrow IF bandwidth setting is 15 Hz.

TEST EQUIPMENT :

1. Calibrated RF signal generator with 0 dBm output.
2. Calibrated frequency counter or meter.
3. Spectrum analyzer, with sensitivity of at least 80 dB below the RF generator output.

----- OR-----

1. Calibrated RF indicator such as a Performance Network Analyzer.
If using a Performance Network Analyzer, ensure to perform a full two-port cal, or Normalize prior to taking the RF measurements.
2. For measurements on depth of Notch frequency, we suggest using a full screen bandwidth of 5 megahertz, and the smallest IF bandwidth as provided on the instrument.
'ie : The smallest IF bandwidth on the HP 8714C analyzer, as used at Telewave, is 15 Hz.

Tools required: 7/16" wrench and nut-driver, medium and small flat-blade screwdrivers.

NOTE: When transmitter power is passing through a cavity, high RF voltages and currents exist on the internal surfaces. Cavity tuning should be performed using a signal generator only. If no other RF source is available, ***use the lowest output power available and make only minimal adjustments.***

Additional Resources for Band Pass Tuning

1. Band Pass, Pass Reject, and Notch Cavity Filters on the DSA815-TG /with James Eagleson of Telewave

<https://www.youtube.com/watch?v=rvKB0UIVvQ8>